

Power Sensors

POWER & ENERGY

Power & Energy Meters

Power Sensors

Energy Sensors

Power & Energy Accessories

Custom & OEM

Calibration & Service

BEAM DIAGNOSTICS & SPECTRAL ANALYSIS

Beam Diagnostics

Spectral Analysis

INDICES

Laser Cross-Reference Index

Part Number Index

Product Name Index

High-Sensitivity Semiconductor Sensors (to 50 mW)*

Semiconductor sensors have very high sensitivity and are ideal for CW laser measurement at the nW to mW power level. These sensors typically saturate in the 10-50 mW range, so for linear operation up to a maximum of 5 watts, a 1000:1 optical attenuator should be used (see page 87).



MODELS LM-2 / OP-2

SPECIFICATIONS	LM-2 UV/OP-2 UV ¹	LM-2 VIS/OP-2 VIS ¹	LM-2 IR/OP-2 IR ¹
Detector Material	Silicon	Silicon	Germanium
Wavelength Range (μm)	0.25 - 0.4	0.4 - 1.06	0.8 - 1.55 / 0.8 - 1.8
Power Range	10 nW - 30 mW	10 nW - 50 mW	10 nW - 10 mW
Resolution (nW)	1	1	1
Detector Diameter (mm)	6	7.9	5
Dimensions (mm)	∅ 29 x 54	∅ 29 x 54	∅ 29 x 54
Calibration Uncertainty	±8%	±5%	±4.5%
Calibration Wavelength (nm)	see note ²	see note ²	see note ²
Cooling Method	Air	Air	Air
Connector Type (LM-2)	LM DB-25	LM DB-25	LM DB-25
Connector Type (OP-2)	OP DB-25	OP DB-25	OP DB-25
Cable Length (m)	1.8	1.8	1.8
Part Number (LM-2)	33-0951-000	33-0936-000	33-0944-000
Part Number (OP-2)	1061322	1061323	1061324

¹ See chart on page 11 to determine compatibility between LM-2, OP-2 and meters.

² Monochromator calibration across wavelength range.

- Si, Ge photodiodes
- 0.25 to 1.55 μm spectral range
- Fiber-optic connector (optional)
- 1000:1 attenuator (optional)

* See the Power and Energy Sensor Compatibility Charts on page 11 for compatibility with meters.



High-Sensitivity Semiconductor Sensors (to 50 mW)

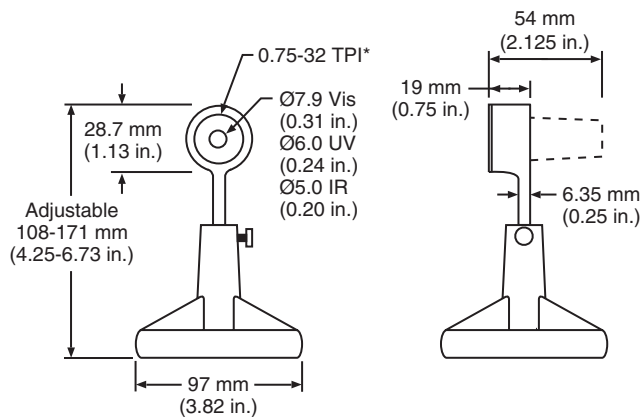

Part Number	Description
33-0951-000	LM-2 UV
33-0936-000	LM-2 VIS
33-0944-000	LM-2 IR

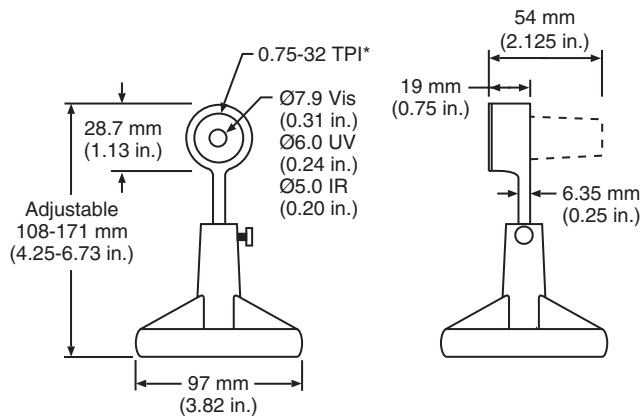

Part Number	Description
1061322	OP-2 UV
1061323	OP-2 VIS
1061324	OP-2 IR

POWER & ENERGY

Power & Energy Meters

Power Sensors

Energy Sensors

Power & Energy Accessories

Custom & OEM

Calibration & Service

BEAM DIAGNOSTICS & SPECTRAL ANALYSIS

Beam Diagnostics

Spectral Analysis

INDICES

Laser Cross-Reference Index

Part Number Index

Product Name Index